



## Consolite® Technology Ltd

St. Martins Business Park, Bells Lane, Zeals, Wiltshire, BA12 6LY, UK

Tel: +44 (0) 1747 840900 - E mail: sales@consolite.co.uk

www.consolite.co.uk - Certified to ISO9001:2015

### CTL-433 Bulkhead Light, LED, Exterior

A rugged light fitting with high versatility due to its compact size and durability. The light is available in a range of light output variants to suit different applications.

#### Features

LED technology - low power, high reliability

High output, neutral colour white light

Rugged construction, 316L stainless steel

96-277V AC input

IP67 rated for full weatherproofing

Simple installation

#### Options

Dual mode, full bright white/dark adaption white or red

NVG compatible

2 cable entries for daisy-chaining

24V (9-31V range), 115VAC and 230VAC versions

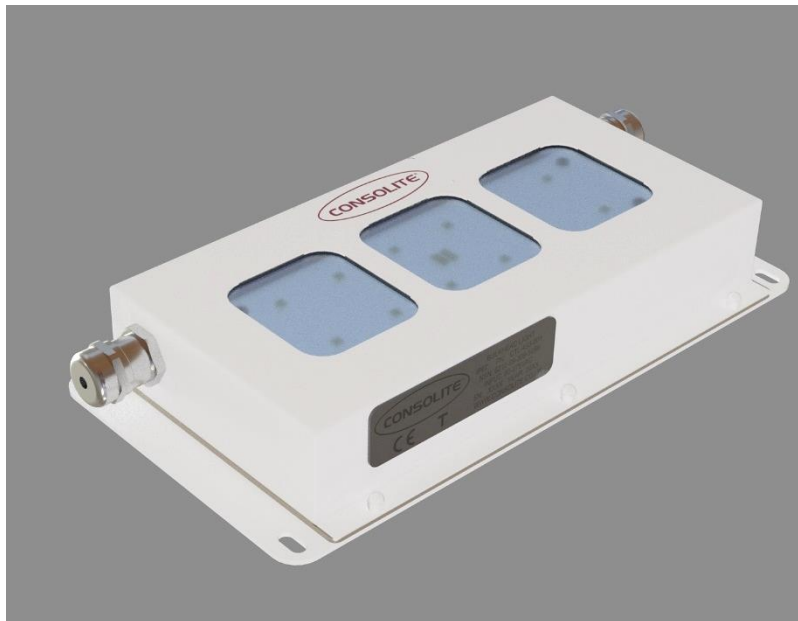



## Consolite® Technology Ltd

St. Martins Business Park, Bells Lane, Zeals, Wiltshire, BA12 6LY, UK

Tel: +44 (0) 1747 840900 - E mail: sales@consolite.co.uk

www.consolite.co.uk - Certified to ISO9001:2015

### Part Number Guide

P/No	Function	Output lm	IP	Voltage V	Power W	Dimensions mm	Weight kg
001	Full bright white	800	67	96-277	<8	272 x 130 x 40	< 3
011	Dual mode – Full bright white and Low-level NVG white	800/25	67	96-277	<8/1	272 x 130 x 40	< 3
021	Low-level white NVG compatible	25	67	96-277	<1	272 x 130 x 40	< 3
041	Red light single mode	300	67	96-277	<5	272 x 130 x 40	< 3
051	Full bright white	800	67	24 DC	<8	272 x 130 x 40	< 3
061	Dual mode – Full bright white and Low-level NVG white	800/25	67	24 DC	<8/1	272 x 130 x 40	< 3
071	Low-level white NVG compatible	25	67	24 DC	<1	272 x 130 x 40	< 3
091	Red light single mode	300	67	24 DC	<5	272 x 130 x 40	< 3

Lumen output and power consumption are approximate and may be subject to change.

### Dimensions

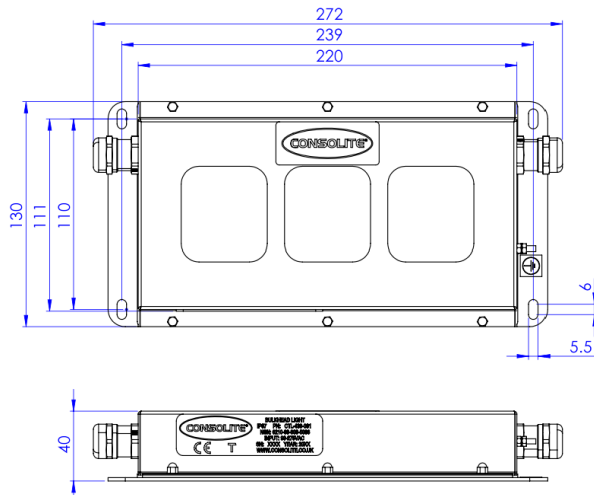

### Standards

NVG compatible IAW Def Stan 02-587 Part 3

EMC compliant to IEC 60945

Environmental testing to MIL-STD-810G

Ocular hazard analysis IAW BS EN 62471:2008

Electrical safety tested IAW BS EN 60598-1

Consolite is a long established leader in night vision lighting for military platforms, designing and manufacturing lighting for NVGs for over 25 years, including lighting for aircraft, ships and ground use.

Consolite's design facility permits the calculation of lighting requirements for any space from a single compartment to an entire ship.

Consolite's test facility includes the latest equipment required for testing night vision compliance to any relevant standard plus goniophotometric equipment for full 360 degree light characterisation of luminaire output.