



Consolite® Technology Ltd

St. Martins Business Park, Bells Lane, Zeals, Wiltshire, BA12 6LY, UK

Tel: +44 (0) 1747 840900 - E mail: sales@consolite.co.uk

Certified to ISO9001:2015

CTL-355 Versatile Ceiling Luminaire

A range of ceiling mounted general lighting LED luminaires, suitable for interior or exterior locations. A versatile design allows for a wide range of applications, including LiFi connectivity, dimming and dark adaptation.

Features

LED technology - low power, high reliability
High output, neutral colour white light
Rugged construction, steel housing
96-275V AC input

Options

Dual mode low level dark adaptation or NVG
PIR attachment
Local dimming switch
DALI room dimming
Emergency lighting with battery backup
Galley variant

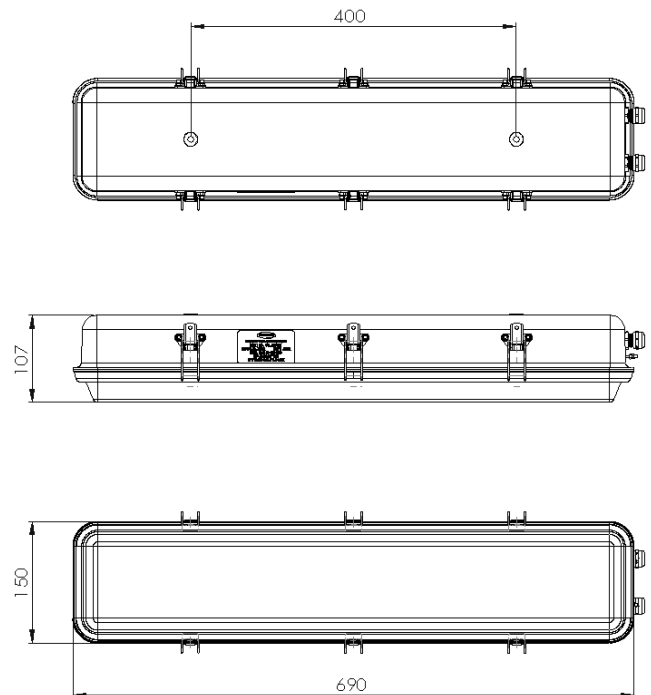



Consolite® Technology Ltd

St. Martins Business Park, Bells Lane, Zeals, Wiltshire, BA12 6LY, UK

Tel: +44 (0) 1747 840900 - E mail: sales@consolite.co.uk

Certified to ISO9001:2015

Part Number Guide

CTL-355	Function	Output (lm)	IP Rating	Voltage (V AC)	Power (W)	Dimensions (mm)	Weight (kg)
-001	Single mode - bright white	2200	65	96-275	28	690 x 150 x 107	4.5
-011	Dual mode - bright white + low level NVG white output (2-5lx)	2200/22	65	96-275	28/5	690 x 150 x 107	4.5
-041	Dual mode - bright white + low level white output (2-5lx)	2200/22	65	96-275	28/5	690 x 150 x 107	4.5
-043	Dual mode - bright white + low level white output (2-5lx) - dimmable *	2200/22	65	96-275	28/5	690 x 150 x 107	4.5
-211	Dual mode - bright white + low level NVG white dark adaptation (2-5lx) powered by a battery backup	2200/22	65	96-275	28/6	690 x 150 x 107	4.7
-401	Single mode - bright white with individual dimming	2200	22	96-275	28	690 x 150 x 107	4.5
-601	Single mode - LiFi-enabled bright white	2200	65	96-275	28	690 x 150 x 107	4.7
-701	Single mode - bright white with motion sensor	2200	65	96-275	28	690 x 150 x 107	4.7
-741	Dual mode - bright white + low level white output (2-5lx) - motion sensor	2200/22	65	96-275	28/5	690 x 150 x 107	4.7
-902	Single mode - bright white - stainless steel housing for galley use	2200	65	96-275	28	690 x 150 x 107	6
-912	Dual mode - bright white + ultra-low level NVG white output (0.5lx)	2200/4	65	96-275	28/5	690 x 150 x 107	4.5
-913	Dual mode - bright white + Low level white output (10lx) - dimmable*	2200/40	65	96-275	28/8	690 x 150 x 107	4.5

* Centralised dimming may be controlled by use of a CTL-462-002 DALI room dimmer unit. Other options may be available. Please enquire.

Light output distribution

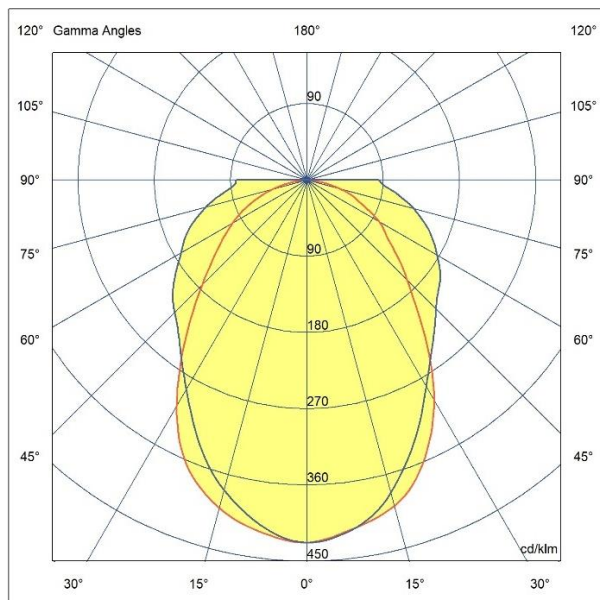

IES/LDT files available on request

Standards

- NVG compliant IAW Def Stan 02-587 Part 3
- EMC, emissions and immunity compliant IAW BS EN 60945
- Electrical safety tested IAW BS EN 60598-1
- Impact tested IAW BS EN 60598-1
- Shock testing to MAP01-470 Grade C,D
- Environmental testing IAW IEC 60068
- Degrees of protection IAW BS EN 60529
- Photo-biological safety IAW BS EN 62471
- Dual Mode Lighting IAW DEF STAN 02-587 Parts 1 & 3
- Total Harmonic Distortion (THD) IAW LR Rules & Regulations
- RoHS Directive IAW 2011/65/EU
- WEEE Producer Registration Number WEE/AU676OYF

Installation

- Installation detailed in CTL-355-INST
- Connection points detailed in CTL-355-XXX-ID & CTL-355-INST

Consolite is a long established leader in night vision lighting for military platforms, designing and manufacturing lighting systems for NVGs for over 25 years, including lighting for aircraft, ships and ground use.

Consolite's design facility permits the calculation of lighting requirements for spaces from a single compartment to an entire ship.

Consolite's test facility includes the latest equipment required for testing night vision compliance to any relevant standard plus goniophotometric equipment for full 360 degree characterisation of luminaire light output.