



## Consolite® Technology Ltd

St. Martins Business Park, Bells Lane, Zeals, Wiltshire, BA12 6LY, UK

Tel: +44 (0) 1747 840900 - E mail: sales@consolite.co.uk

Certified to ISO9001:2015

### CTL-426 Bunk Light, LED, Interior

A low profile LED bunk light fixture with adjustable white light.  
Robust steel design, with dimming controls and two USB charging ports.

#### Features:

- LED technology - low power, high reliability
- Warm white light, dimmable
- Rugged construction, folded and painted stainless steel body
- Low profile front panel
- 2 USB-A ports for connecting and charging devices, each able to deliver 5V at 1 Amp
- Electronic control to prevent run away charging





# Consolite® Technology Ltd

St. Martins Business Park, Bells Lane, Zeals, Wiltshire, BA12 6LY, UK

Tel: +44 (0) 1747 840900 - E mail: sales@consolite.co.uk

Certified to ISO9001:2015

## Part Nos

	Input Voltage (V AC)	Light Output (lm)
CTL-426-001	115	100
CTL-426-010	230	100
CTL-426-011	230	200

## Installation Data

Dimensions (mm)	200 x 130 x 33.5 (recessed installation, front panel protrudes 1.5mm)
Weight (kg)	0.75
Light Output	Warm white light (3000K)
Material	Stainless Steel, with Traffic White (RAL 9016) graphic
IP rating	IP44 when fitted to the bulkhead and USB bungs fitted

## Standards:

Electrical Installations in ships: Luminaires and Lighting Accessories IAW BS IEC 60092-306

Incorporating the following:

- Degrees of protection provided by enclosures IAW BS EN 60529
- Electrical Safety IAW BS EN 60598-1
- Impact (Mechanical Strength) IAW BS EN 60598-1
- EMC, emissions and immunity IAW BS EN 60945
- Environmental testing IAW IEC 60068

Luminaires for emergency lighting IAW BS EN 60598-2-22

Photo-biological Safety of Lamps and Lamp Systems IAW BS EN 62471

Night Vision Device (NVD) compatibility IAW DEF STAN 02-587 Part 3

Total Harmonic Distortion (THD) IAW Lloyds Rules and Regulations 2018

Mechanical Shock in Naval Vessels IAW MAP 01-470

RoHS Directive IAW 2011/65/EU

WEEE Producer Registration Number WEE/AU6760YF

## Installation:

Installation details can be found in CTL-426-XXX-INST.

Connection details can be found in CTL-426-XXX-ID & CTL-426-XXX-INST.

## Dimensional drawing

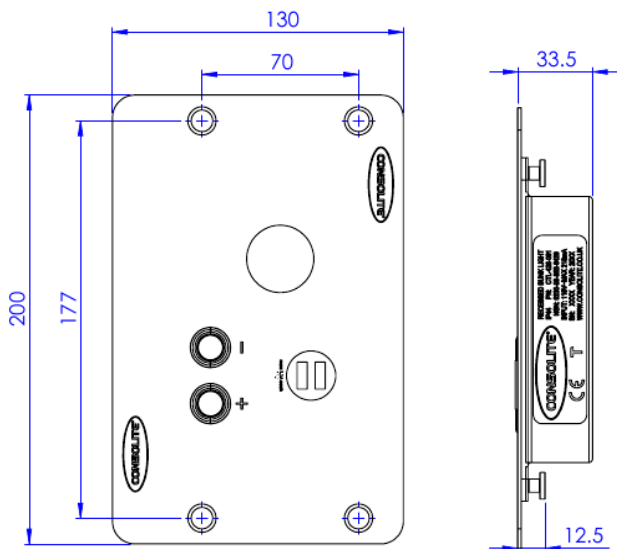

Consolite is a long established leader in night vision lighting for military platforms, designing and manufacturing lighting for NVGs for over 25 years, including lighting for aircraft, ships and ground use.

Consolite's design facility permits the calculation of lighting requirements for any space from a single compartment to an entire ship.

Consolite's test facility includes the latest equipment required for testing night vision compliance to any relevant standard plus goniophotometric equipment for full 360 degree light characterisation of luminaire output.